

### SEPAL 1

DESCARGA ARENA	200 X 320 mm
DIÁMETRO EXTERIOR DEL TORNILLO	280 mm
POTENCIA kW	0,37
CARGA DINÁMICA A PLENA CARGA	2200 daN

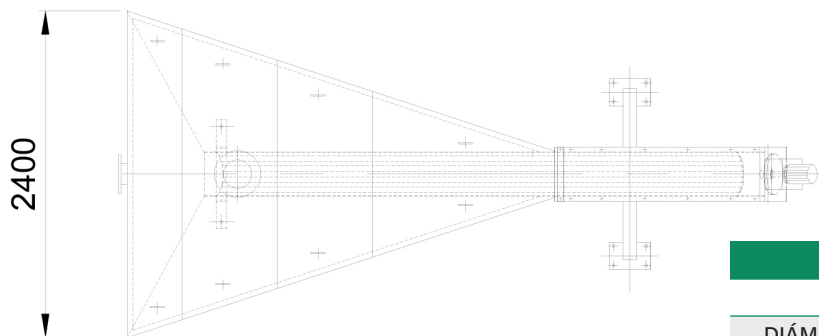
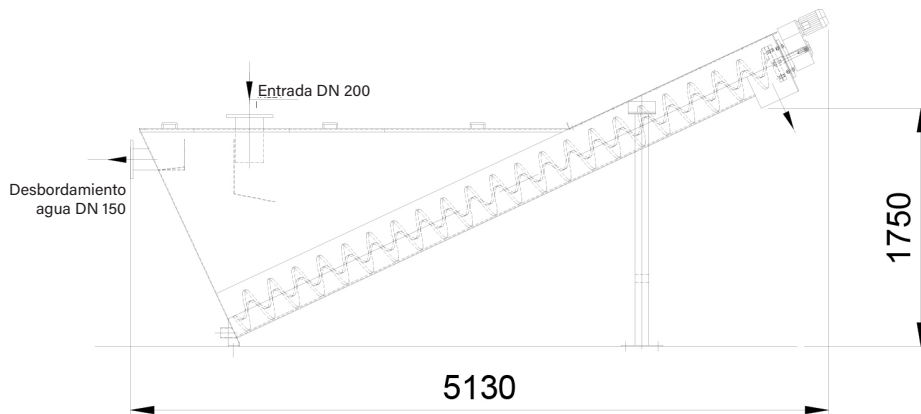

### SEPAL 2

DESCARGA ARENA	300 X 320 mm
DIÁMETRO EXTERIOR DEL TORNILLO	280 mm
POTENCIA kW	0,55
CARGA DINÁMICA A PLENA CARGA	4300 daN