

Modello	Ø est. girante	Motori Kw	Ø ingresso	Ø uscita impasti	Ø uscita scarti	A	B	C	Carico statico con pasta
1,2	33"-840mm	75	DN 350	DN200	350mm	1050mm	2600mm	300mm	7000daN
2,5	42"-1065mm	90-110	DN350	DN250	400mm	1150mm	2900mm	350mm	7500daN
3	50"-1270mm	110-132	DN400	DN300	500mm	1220mm	3200mm	400mm	8800daN
3,5	50"-1270mm	132-160	DN500	DN350	600mm	1300mm	3200mm	510mm	9400daN

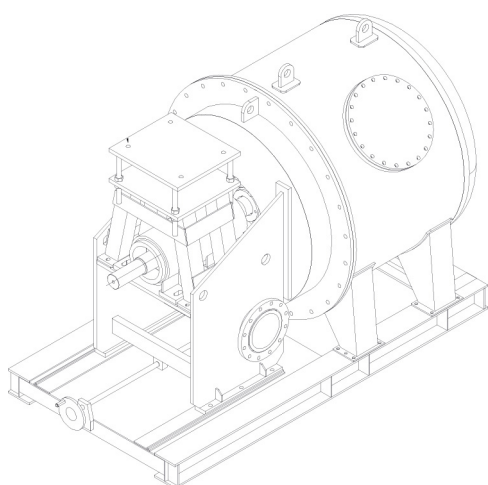

Modello	Installazione tipica con LD pulper
1,2	15m ³ - 20m ³
2,5	20m ³ - 30m ³
3	30m ³ - 40m ³
3,5	40m ³ - 70m ³